

Elettropompa HD1115R - 610002

Motorpump HD1115R - 610002

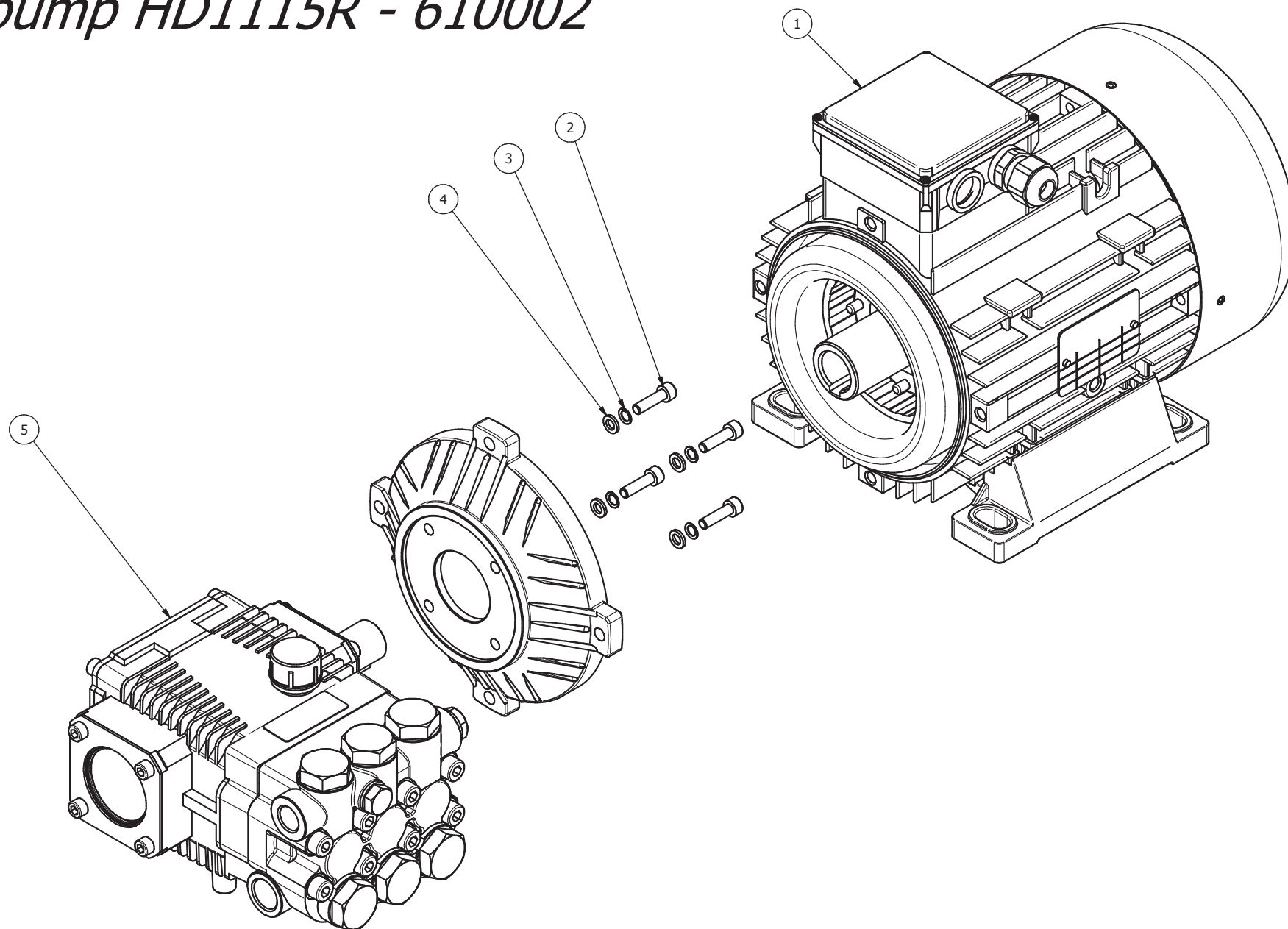

ELETTROPOMPA HD1115R - 610002 / MOTORPUMP HD1115R - 610002

PRESSIONE MASSIMA / *MAX PRESSURE* : 140 BAR

PORTATA A 1450 RPM / *FLOW RATE AT 1450 RPM* : 11 l/min

PORTATA A 1740 RPM / *FLOW RATE AT 1740 RPM* : 13.2 l/min

POTENZA MASSIMA A 1450 RPM / *MAX POWER AT 1450 RPM* : 3 kW

POTENZA MASSIMA A 1740 RPM / *MAX POWER AT 1740 RPM* : 3.6 kW

PESO / *WEIGHT* : 29 kg

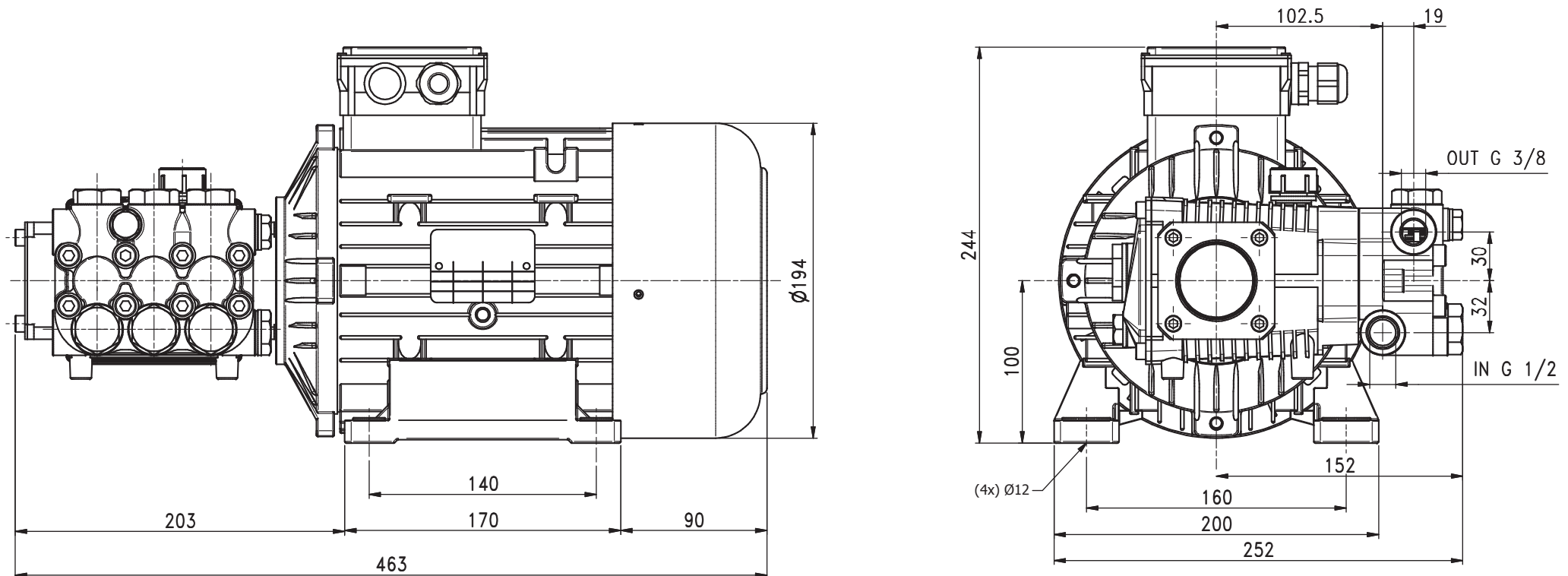

ELETTROPOMPA HD1115R - 610002 MOTORPUMP

PARTS LIST

LISTA PARTI

Pos. Item	Codice Part Number	Description	Descrizione	Q.tà Q.ty
1	5800.08	Electric Motor	<i>Motore Elettrico</i>	1
2	1801.26	Screw M6x22	<i>Vite TCEI M6x22</i>	4
3	1401.02	Spring washer Ø6	<i>Rosetta elastica Ø6</i>	4
4	1400.02	Washer Ø6.4	<i>Rosetta Ø6.4</i>	4
5	HD1115R	Pump	<i>Pompa</i>	1

Elettropompa HD1415R - 610003

Motorpump HD1415R - 610003

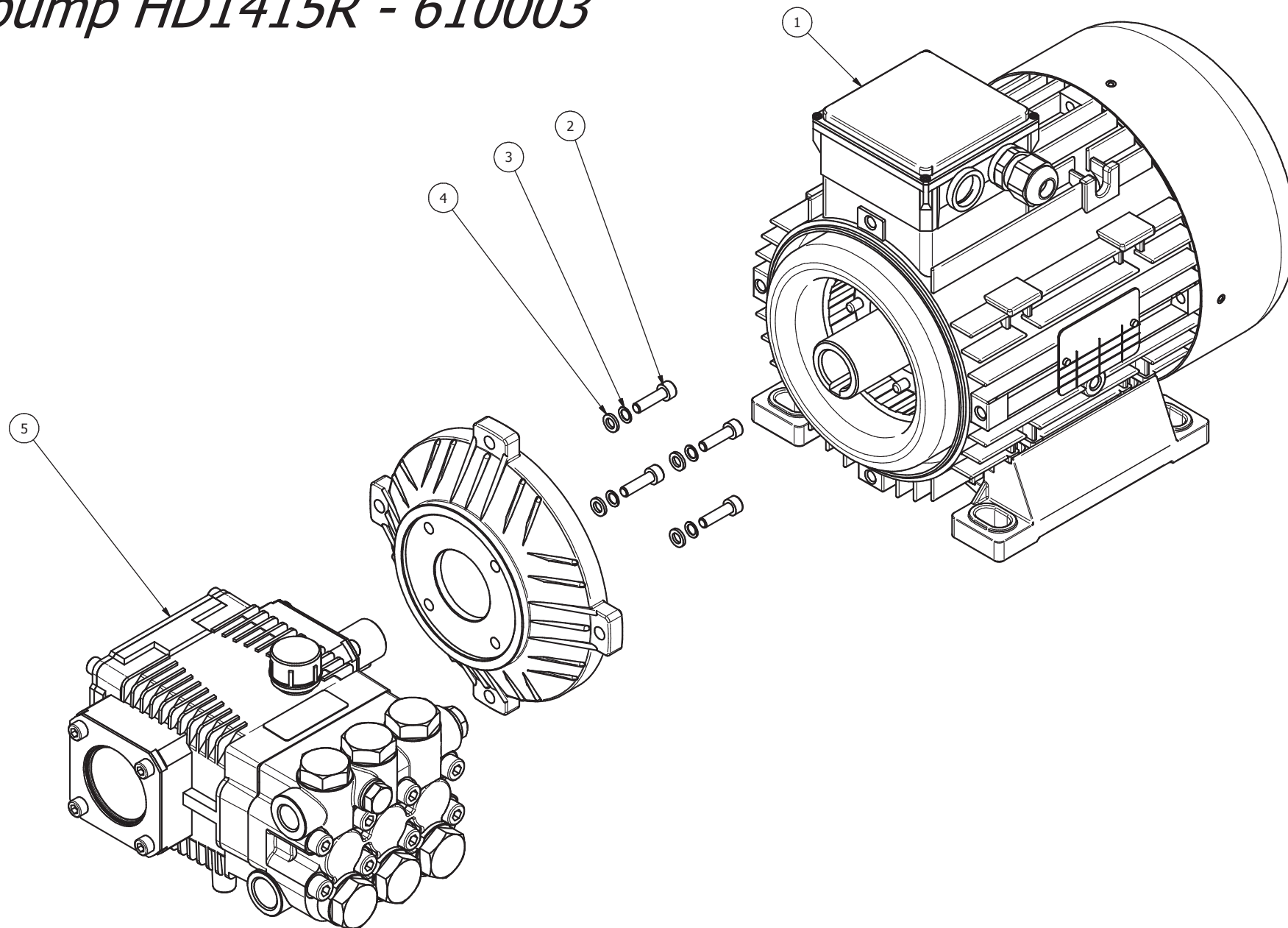

ELETTROPOMPA HD1415R - 610003 / MOTORPUMP HD1415R - 610003

PRESSIONE MASSIMA / *MAX PRESSURE* : 150 BAR

PORTATA A 1450 RPM / *FLOW RATE AT 1450 RPM* : 14 l/min

PORTATA A 1740 RPM / *FLOW RATE AT 1740 RPM* : 17 l/min

POTENZA MASSIMA A 1450 RPM / *MAX POWER AT 1450 RPM* : 4 kW

POTENZA MASSIMA A 1740 RPM / *MAX POWER AT 1740 RPM* : 4.8 kW

PESO / *WEIGHT* : 29 kg

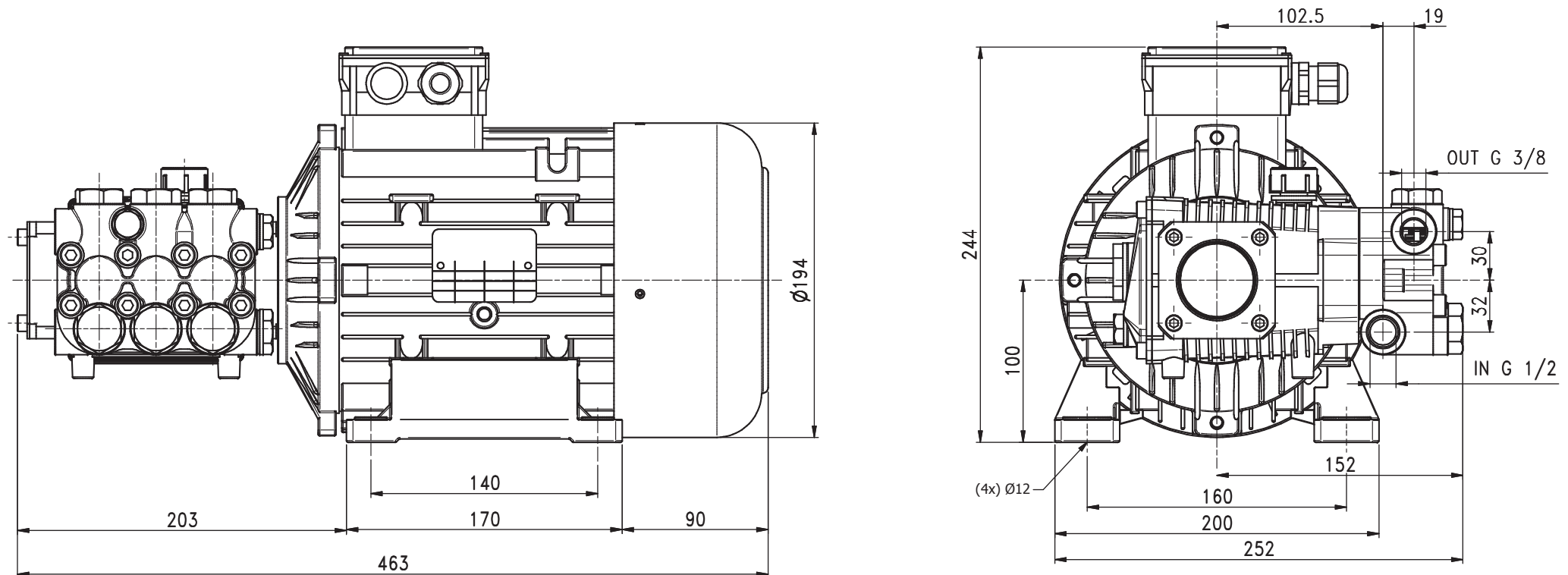

ELETTROPOMPA HD1415R - 610003 MOTORPUMP

PARTS LIST

LISTA PARTI

Pos. Item	Codice Part Number	Description	Descrizione	Q.tà Q.ty
1	5800.04	Electric Motor	<i>Motore Elettrico</i>	1
2	1801.26	Screw M6x22	<i>Vite TCEI M6x22</i>	4
3	1401.02	Spring washer Ø6	<i>Rosetta elastica Ø6</i>	4
4	1400.02	Washer Ø6.4	<i>Rosetta Ø6.4</i>	4
5	HD1415R	Pump	<i>Pompa</i>	1